

Dear Contestant,

Welcome to the 31th Annual Popsicle Stick Bridge Competition (PSBC). For the past thirty years, the Younger Member Forums of the Los Angeles Section of the American Society of Civil Engineers (ASCE) have been organizing this annual event for high school students. This event has only been possible thanks to the help of other engineering organizations and the support of the local engineering community.

This event is designed as a fun way for high school students to develop engineering skills through critical thinking, problem-solving, teamwork, and creativity. It teaches students about the civil engineering profession and introduces them to some of the challenges and triumphs that civil engineers face in their careers. The competition winners will be awarded scholarships for their efforts. We hope that this competition sparks each student's interest in civil engineering and opens new doors to pursue math, science, and/or engineering-related careers.

We are happy to announce that this year's competition will be **in person** at **California State University, Long Beach**. So we will test the bridges in person and do all presentations in person as well. Every step of this process takes into account the safety and health of all participants.

The in-person event will be held on **Saturday, April 19th, 2025 starting at 8:00 AM PST**. Let's get building!

Enclosed in this handbook is all the information necessary to participate in this competition. Please read through this handbook carefully to make sure that you and/or your team follow all the rules and requirements.

On behalf of the PSBC Committee, best of luck to you all! If you have any questions or concerns, please do not hesitate to contact us at: popsicle.bridge@gmail.com.

Sincerely,

Your 2025 Popsicle Stick Bridge Committee:

Brisa Bernal, *CSUF, ASCE OC PSBC Co-Chair, CSUF Practitioner Advisor*

Jacob Perea, *CSUF, ASCE OC PSBC Co-Chair*



CHALLENGE PROMPT

Prospective engineers, we are Civil Engineers in the State of California. Our organization builds bridges to provide excellent transportation systems for traveling motorists, bicyclists, and pedestrians all over the state.

Our mission is: *Provide a Safe, Sustainable, Integrated, and Efficient Transportation System to Enhance California's Economy and Livability.*

We hope to inspire you to become **Engineers** and help us find solutions for challenges in our everyday world.

Our fellow residents in Orange County need your help to create better access throughout the county. As we identify an infrastructure that is at times designed around vehicular roads and transportation, we need to find a balance between pedestrian and cyclist and vehicular commuters to meet the varying needs of our population. You as future engineers are posed with the challenge of designing and constructing a new Pedestrian Overcrossing Bridge that will be used by bikers and pedestrians. Your task is to develop a LIGHTWEIGHT, STRONG, and FUNCTIONAL bridge that bikers and commuters can use during their daily routines.

The challenge for you is to create a working model to demonstrate your ingenuity. Remember, the bridge must be light in weight to minimize its cost, and strong enough to bear the weight of its users. With popsicle sticks, glue, and some good creativity we believe you can create a wondrous bridge. Good luck and we look forward to seeing what you have in store.



Long Beach International Gateway Bridge OVERVIEW

As a participant in this year's Popsicle Stick Bridge Competition, teams will consist of 2 - 4 individuals per team on the design and construction of a model bridge made solely from typical wooden craft sticks (popsicle sticks) and all-purpose white school glue (*refer to the Rules section of this handbook for a full list of materials and requirements*). Your objective is to build the **lightest** bridge that can carry the **maximum load (200 lbs)**.

The competition is open to all high school students in Southern California, which includes the Counties of Los Angeles, Orange, San Bernardino, Riverside, Ventura, Santa Barbara, San Luis Obispo, Inyo, Mono, and Kern. The bridges are to be designed and constructed before the competition date, which is scheduled for **Saturday, April 19th, 2025**.

Teams will be awarded points based on the performance of their bridge in different categories of the competition *Strength, Efficiency, Workmanship, and Presentation, as well as an Impromptu Design Event*. At the end of the competition, all points will be added and the scores of all the competing teams will be compared. A maximum total of **100 points is possible** in this competition. Distributions of points are as follows:

1. **Bridge Strength and Efficiency [35 points]:** Top points awarded to the team with the **lightest weighted bridge** that can carry the most weight, and is the most **efficient bridge***. Bridges will be ranked by the maximum load they sustain during the test.
2. **Bridge Workmanship [10 points]:** Awarded based on the bridge's level of craftsmanship.
3. **Presentation [30 points]:** Awarded based on the team's presentation of their bridge's planning, design, and building process most creatively and professionally.
(Note: 15 points for presentation and 15 points for the display board.)
4. **Technical Report [20 points]:** Awarded based on the team's technical report that describes the planning, design, and construction phase of their bridge.

5. **Impromptu Design Competition [5 points]:** Awarded to each team based on their ability to perform a task assigned on the day of the event without any prior knowledge of the materials or the objective.

See official competition rules for detailed scoring/rule violations/deductions.

* Efficiency is calculated, as;

$Efficiency = Peak Load Sustained / Weight of bridge$

i.e. 150 lbs. / 2.32 lbs. = 64.65 Efficiency

Larger Efficiency number indicates a more efficient and better-performing bridge design. Awards will be given to the teams that are ranked *first, second, and third* place considering an overall score as well as in the individual categories. Award prizes will be distributed after the virtual event.

Plagiarism of any kind will not be tolerated. All work submitted/presented must be original to this year's competition rules and **may not be reused or recycled from previous years**. If it is observed that the bridge design idea, concepts, and presentations of any teams have the same or similar information, all the teams involved will be **disqualified**. The sponsoring teacher will immediately be notified, and the **disqualified** teams will not be scored and judged during the competition.

REGISTRATION INFORMATION

Please find the registration link on the [OC YMF PSBC Homepage](#).

Registration fee \$10 per team, non-refundable.

Registration Open – Starting NOW until **Friday, January 3rd, 2025**.

Questions? Please Feel Free to Reach out!

In order to help facilitate any questions about registration, rules, etc. we have created the following email addresses. Please email: popsicle.bridge@gmail.com

MISSION

To provide an exciting, challenging, and educational experience to the students while teaching them, through hands-on activities, the many wonders of civil engineering as a profession.

This will be accomplished by:

- Promoting engineering skills – not only the technical aspects of problem-solving but also emphasizing the importance of teamwork and communication.
- Creating opportunities for interaction among students, teachers, and the engineering community.

CONTEST STAGES

This contest is created by engineering professionals to replicate the experience of designing and building an engineered solution to a problem. The three stages to create a winning bridge, similar to the design of an actual bridge, are

Stage 1 – Planning & Design

Stage 2 – Construction

Stage 3 – Presentation

STAGE 1: PLANNING & DESIGN

The first and most basic stage of the competition is the **Planning and Design Stage**. This is a stage often neglected by contestants that are eager to get started on the construction of their bridge as soon as possible. That type of approach is not recommended; instead, plan out your design. Use the science and math skills you have learned in school to come up with a few bridge concepts. Pay close attention to the topics of load distribution, tension, compression, and trusses. Your sponsoring teacher will be a very valuable resource at this stage as they are your most readily available source of information on the subject. Do some research on different bridge types, search the Internet for helpful information, or talk to engineers for ideas on your bridge concepts. Feel free to reach out to us with any engineering questions.

The Planning and Design Stage can be broken further into a few smaller stages: research, design selection, and plan preparation.

Research

Research is the foundation for the entire process. Use this stage to become familiar with the many different types of bridges and the types of circumstances in which each type is used. Also, try to determine which of these types can be most easily constructed with the materials allowed in this competition. For example, suspension bridges are used to span the largest distances between supports; however, you would be hard-pressed to imitate the behavior of a suspension bridge using nothing but wooden craft sticks and all-purpose glue.

Design Selection

Once you feel comfortable with your understanding of bridges, you can enter the design selection phase. In this stage, you will narrow down your options by eliminating the types of bridges that are not suitable for the specific circumstances and desired results of this competition. If you have enough time to do so, your team may want to experiment with a few designs and carry them into the construction stage before deciding on the final design of your bridge.

Preparing Plans

The final phase of design is plan preparation. What will your bridge look like? How will the craft sticks be arranged? Schematic drawings and plans are valuable tools that engineers use to help them visualize their ideas. Try putting down some of your designs on paper; it will help you see more clearly how your bridge will handle the forces applied. These drawings will also help you during the presentation portion of the competition (as visual aids).

STAGE 2: CONSTRUCTION

While the Planning and Design stage challenges your ability to research new ideas and your fundamental understanding of physics concepts, the construction stage is an exercise in craftsmanship, resourcefulness, and patience. Turning your design sketches into physical models requires good visualization skills and some creative problem-solving as you try to tackle some of the often-unforeseen problems that come up during this stage.

- How can we hold the sticks together while the glue dries?
- How can we keep the weight of my bridge to a minimum?
- How do we choose which sticks to use (and not use)?
- Which sticks should be glued together first?
- How do we make sure that I am gluing the sticks at the proper angles?
- Will the pieces fit together when we are done building them?

These are some of the questions that may come up during construction, and they parallel many of the questions that Civil Engineers face when trying to bring their design off the drawing board and into the real world.

Two structures made of the same materials and following the same set of plans will not necessarily behave the same when subjected to load tests. This is because the quality of construction, and to some extent, the quality of materials, will vary from one to the next. This holds true for your popsicle stick bridge as well; coming up with the strongest design on paper does not guarantee you will have the strongest bridge.

Since you don't have much control over the quality of the wood in your popsicle sticks (however, there are several different manufacturers of craft sticks...), the best thing you can do to regulate the quality of your material is to choose sticks with the fewest visible flaws. Moreover, you have complete control over your construction methods, so make sure you give them the proper attention. Keep in mind that most of the bridges in competition collapse due to **joint failure**, not member failure (i.e. most breaks occur at popsicle stick connection points).

We encourage you to allow ample time during this stage to test out different methods and configurations. Feel free to ask your mentors and teachers for advice, but don't be afraid to test out your ideas. You may find that the best solutions are often found by trial and error.

As you work through this stage, you will see some of the practical applications of the concepts you researched in your design. Explore these concepts thoroughly if you can. We recommend that you build small structures and test their reaction to applied loads using textbooks or other weights and compare their behavior to the predicted results.

Once you begin the construction of your competition bridge, carefully review and re-review the contest rules. It would be very unfortunate if you spent all that time and effort designing and building your bridge just to have point deductions due to minor rule violations.

Carefully manage the weight of your bridge and the usage of glue (a total of no more than 50% of each plane side of each stick may be glued to other sticks). For a full description of the rules and requirements, please refer to the "Rules" section of this handbook.

Most important, however, is to not forget to have fun! Every member of your team should have the opportunity to get involved. Discuss the merits as a team and have fun testing it out to illustrate the conclusions. Do not just strike down ideas that seem like they will not work, discuss their merits as a team and have a little fun testing them out to illustrate your conclusions.

STAGE 3: PRESENTATION

Contrary to what some may think, one of the most critical skills an engineer can have is the ability to effectively communicate technical material in a clear and compelling manner.

Engineers are often the people best equipped with the knowledge of the technical aspects of a project. Because of this, they are often required to present the aspects of a project to the owner, contractor, regulators, or other stakeholders. The image of the engineer hunched over a computer crunching out numbers all day is outdated. Through the presentation stage, we hope to provide an engineering challenge like real-world applications while helping students develop their communication and presentation skills.

As part of the presentation of your bridge, you will be expected to write a technical report. Technical writing skills are essential to all engineers and will be used every day in a career in engineering. Whether working to prepare specifications for the proper manufacture of a product, organizing research data so that others can benefit from your work, or even creating a set of standard procedures and guidelines, engineers must be able to write in a manner that is **clear, concise, and well organized**.

For this competition, you will be creating a case history report documenting the design and construction process of your popsicle stick bridge. In it, you will describe the problems encountered in each stage and the steps taken to solve them. The reports will be judged

based on content, structure, and grammar, so pay close attention to all these aspects while writing.

In addition to your written report, you will also be preparing a visual display for your bridge. The display should include plans and/or schematic drawings of your design illustrating how it works. It should also have pictures of the construction process. However, while the written report should be very technical in nature, the display is your opportunity to impress the judges with your artistic creativity. We encourage you to be as creative as you want to be in designing your display; make up a set for your bridge or even a background story to go with it. The displays will be judged based on creativity and craftsmanship so go ahead and give the right side of your brain a little workout.

Finally, on the day of the event, your team will give a five (5) minute oral presentation summarizing the entire bridge-building experience to a panel of judges. The following questions should be addressed during your presentation:

- How was the design of the bridge chosen?
- What construction sequence was used? List step-by-step construction procedures.
- When the bridge is loaded how is the load transferred to the supports/foundations?
- What was the most difficult part of building the bridge?
- What lessons did you learn from the design and construction process?
- How has this project affected your engineering view?

All members of the team will be expected to participate in the presentation and demonstrate a firm understanding of the design and construction processes. There is no set format for the oral presentations, so you may choose to approach it in any manner you wish, as long as you cover the required points. Please note that no power sources will be provided on the day of the event, so neither your presentation nor your display board should contain elements that require an electric outlet.

For a complete list of requirements, please refer to the “Rules” section of this handbook.

OFFICIAL COMPETITION RULES

Please review the following rules carefully to make sure that your bridge, report, and presentation comply with all of them. **No exemptions will be given on the day of the event.** If you wish to challenge or discuss any rules, please contact the contest organizers **before Friday, March 28th, 2025** (See the first page of this handbook for contact information).

General Rules

- Popsicle Bridges, Reports, and Displays found in violation of any of the rules stated hereunder will be assigned a penalty as described in the “Rule Violation” Section.
- If there are egregious violations of the rules, the judges reserve the right to disqualify a team, or award zero points in any category.
- Volunteers and Judges will not provide any materials to participants.
- **Plagiarism of any kind will not be tolerated.** Any teams identified to have similar or the same Technical Reports and Displays will be **disqualified** without any discretion.
- All conflicts will be resolved by the Head Judge.
- **The Head Judge’s decisions are final.**

Competition Teams

- Each school may enter up to **six** teams, consisting of two to four students per team.
- All members of a team must be from the same school.
- Students may not be members of more than one team.
- Each team may only submit one bridge for competition.
- Each report must be unique, written, and submitted by members of that team. No reports should be the same or similar. Plagiarism of any kind will result in immediate disqualification from the entire competition.

Rule Violations: Teams not adhering to these rules are subject to point deductions and potential disqualification from the competition.

Bridge Materials

- Only white all-purpose glue may be used to hold together all bridge elements.
- All bridge elements must be made of common wooden craft sticks (standard size: $4\frac{1}{2}'' \times \frac{3}{8}'' \times \frac{1}{12}''$).
- Each stick has 4 plane sides. (two $4\frac{1}{2}''$ and two $\frac{1}{12}''$)

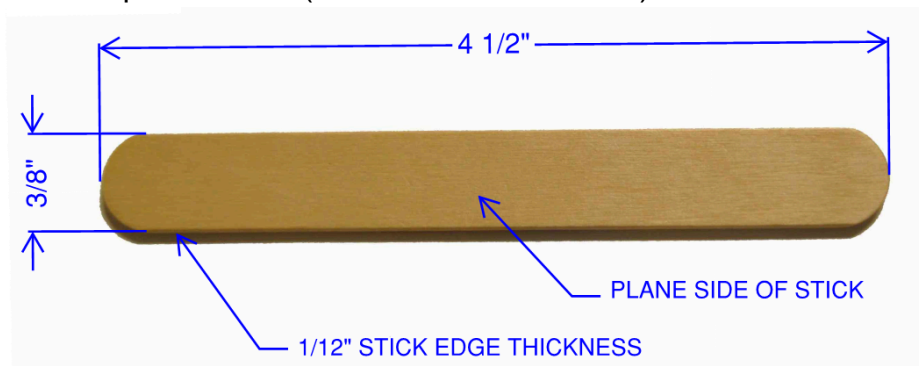

Figure 1 - Common Wooden Craft Stick

Rule Violations: Bridges constructed out of any materials not listed above will be awarded 0 points for the Strength and Efficiency (35) Category.

Bridge Construction

- Bridges must be constructed before arrival at the competition; no modifications will be allowed after registration.
- Bridges will be weighed at the start of the competition
- No more than 50% of a plane side of a stick may be glued to other sticks (i.e. 50% of each side of all sticks must remain unglued).

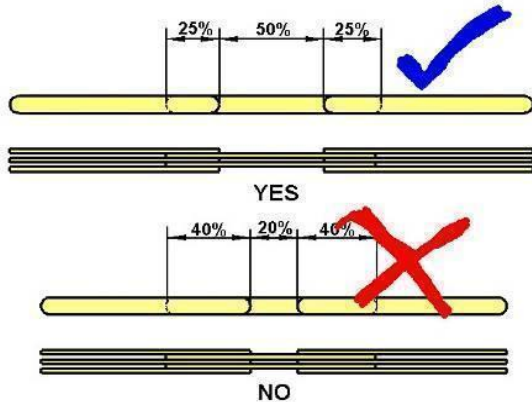

Figure 2 - "50% Rule" Restrictions

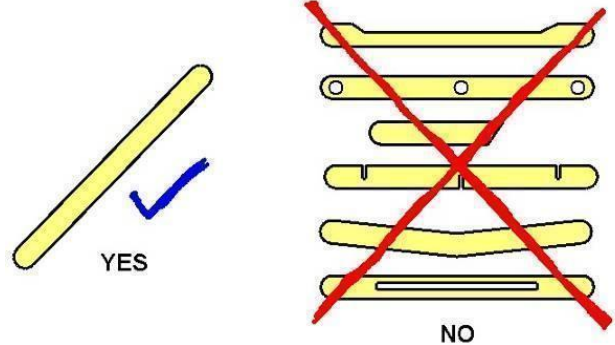

Figure 3 - Stick Alteration Restrictions

- Craft sticks may not be altered or modified in any way, with the following exceptions:
 - Roadway sticks may be cut and/or sanded (but roadway must adhere to all dimension requirements). Roadway sticks are defined as those which will come in contact with the wheels of the toy truck as it crosses over the bridge.
 - Sticks may be lightly sanded to remove the waxy film before gluing.

Rule Violations: Bridges found in violation of the "50% Rule" will be subject to point deductions based on the judge's discretion. A minimum of 10 points will be deducted for the occurrence of the "50% Rule" violation. Egregious violations of the "50% Rule" will be awarded 0 points for the Strength and Efficiency (35) Category.

Bridge Dimensions

- Bridge loading machine supports a minimum span of 37" and a maximum span of 47" See Figure 4 below.
- Bridge height shall not exceed 20-inches. Refer to Figure 6 below.
- Bridge roadway must be continuous, flat, and level. The roadway shall maintain gaps to avoid violating the 50% rule. Refer to Figure 2 above.
- No vertical truss members are to extend below the bottom of the roadway (e.g., no bottom truss bridge designs; roadway shall be the lowest component of the bridge)
- Bridge roadway must have a minimum 4-inch width and a minimum 12-inch height clearance throughout to accommodate bridge use. Refer to Figure 6 below.

- Bridges must have a clear 1.5-inch x 1.5-inch opening along its center from top to bottom. Popsicle sticks can be cut only for this opening. Refer to Figure 5 below.
- Downward continuous load will be applied at the 1.5" x 1.5" opening located at the center of the bridge. Do not obstruct the opening, loading apparatus must be placed at this location. Refer to Figures 7 and 8.
- Only the loading machine end supports may be used to support your bridge, no other surfaces. Refer to Figure 7.
- No portion of the bridge construction shall extend below the end support elevation.

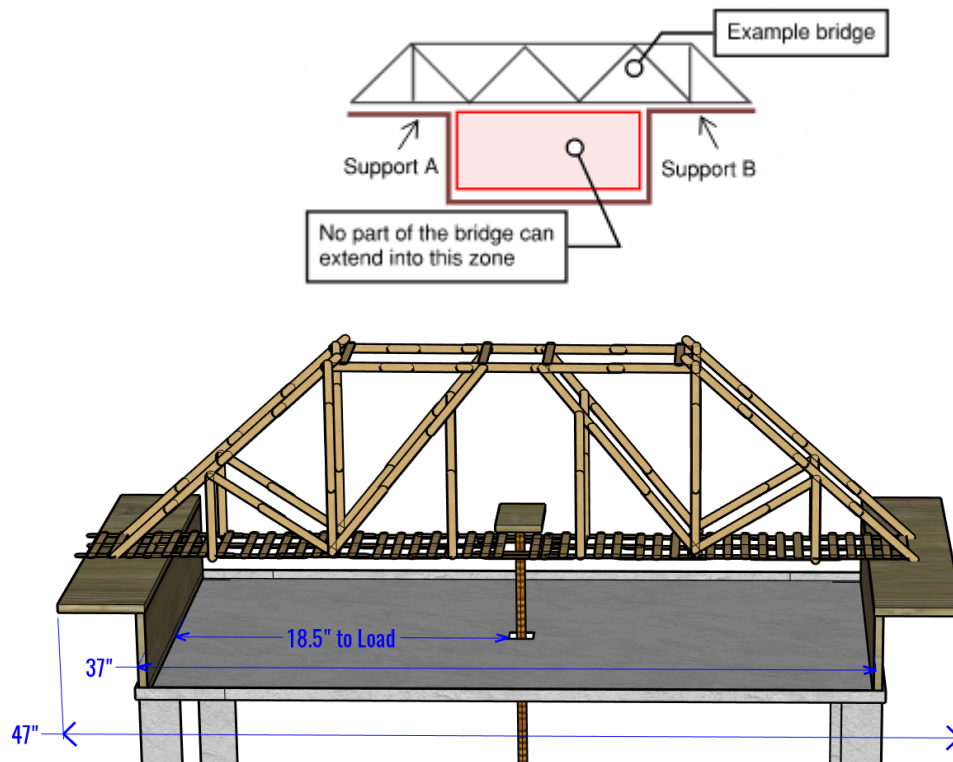

Figure 4 - Profile view of the bridge (not to scale)

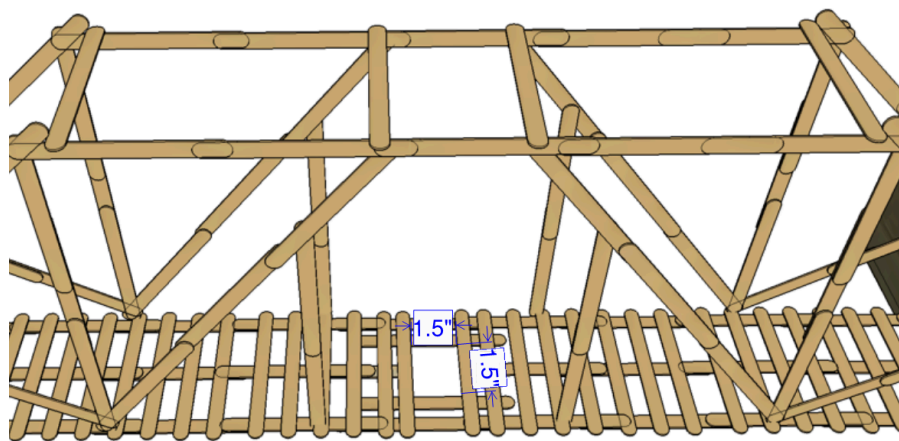

Figure 5 - Center 1.5" x 1.5" Opening Requirement (not to scale)

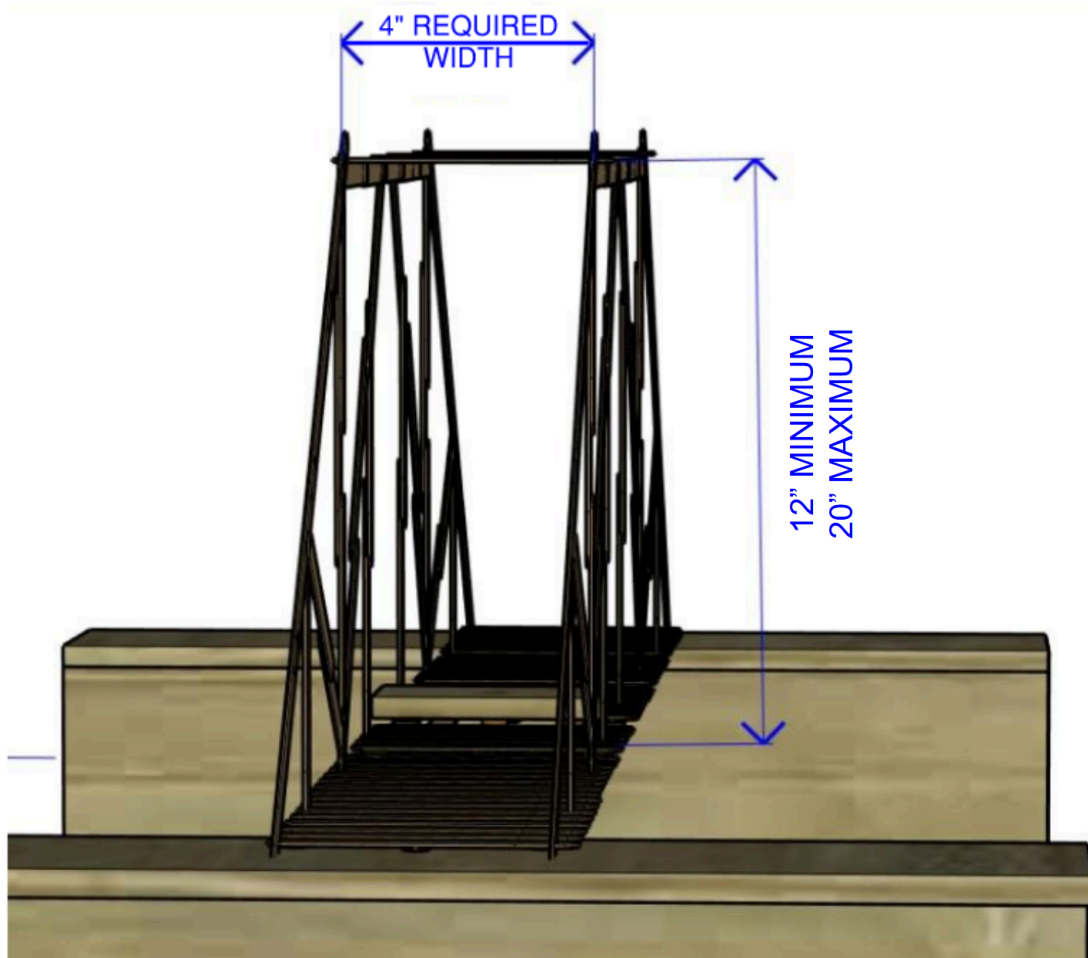

Figure 6 - Roadway Clearance and Height Requirements (not to scale)

Rule Violations: There will be a 10-point deduction on the overall score (up to 50 points) for each dimension not met (i.e., if the bridge width is too narrow in width and too short in length, there are two (2) deductions for a total of a 20 point deduction).

Strength and Efficiency (Loading) [35 Points]

- The location of the load application will be at midspan and through the hole opening.
- Bridges must accommodate the loading apparatus (3"x3" plate) which needs to be inserted EITHER through the top of the bridge or the side of the bridge to be placed directly over the 1.5"x1.5" opening which will be used to connect to the bottom loading cable and winch**. See Figures 7 and 8.
- The loading area must be clearly marked on the bridge.
- The ends of the bridge shall be clearly marked "A Top" and "B Top".
- Bridges will be loaded until failure or until reaching the 200 lb maximum, whichever comes first and the value will be recorded by the digital force reader.

Rule Violations: Bridges that cannot accommodate the loading apparatus or testing rig will be awarded 0 points for the Strength and Efficiency (35) Category.

**All bridges will be loaded at the same winch speed and read by a digital force gauge.

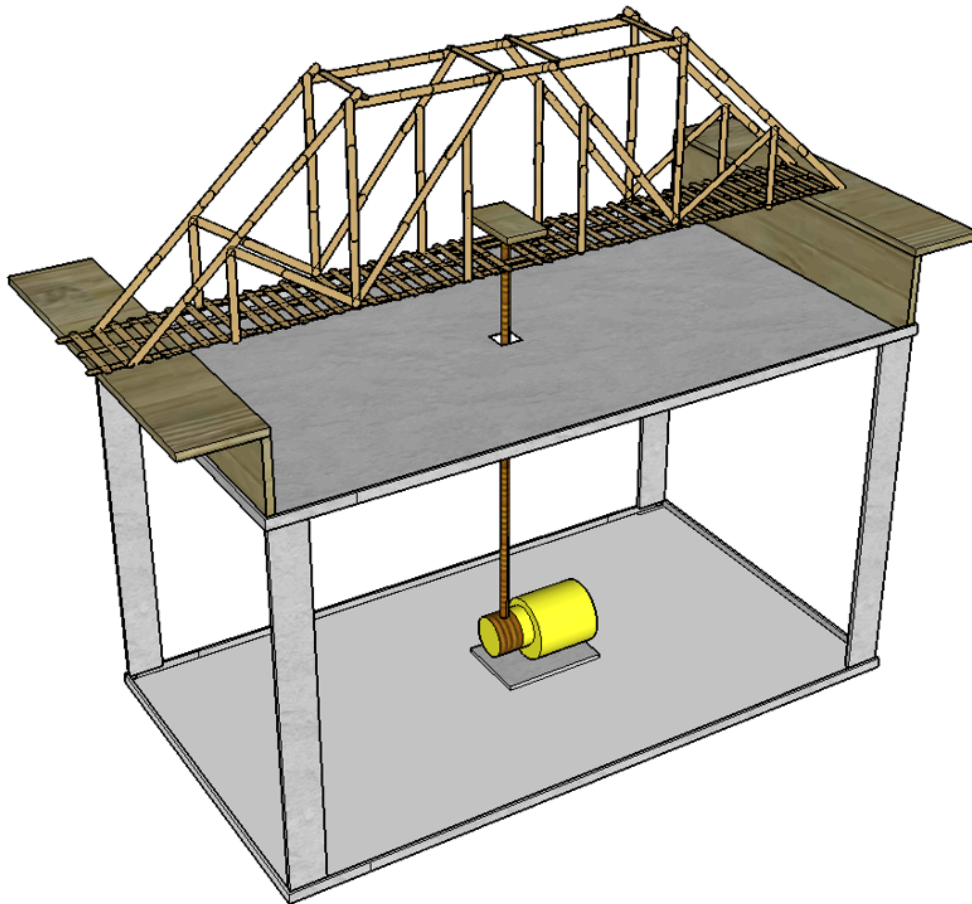

Figure 7 - Loading Configuration

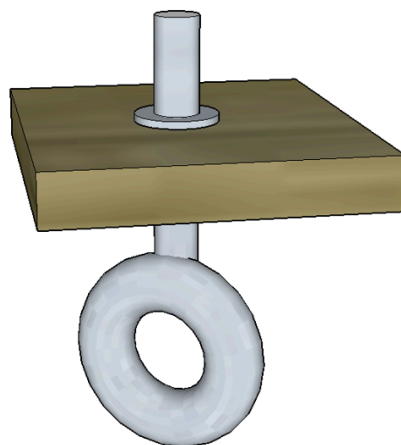

Figure 8 - Loading Apparatus

Oral Presentation [15 Points]

- Shall be a maximum of 5 minutes long.
- Every team member must speak in the presentation.
- Must address the questions stated in “Stage 3: Presentation and Report” from *Contest Stages*.
- Should briefly explain the design selection process and the construction stage and describe the problems encountered.
- No electronic devices or moving displays are allowed. Props are permitted; however, no power source will be provided. Presentations may not attach anything to the wall.

All presentations will be judged by local members of the engineering and construction community. Presentations may be followed by a brief question and answer (Q & A) session, at the discretion of the judges. Note that the question and answer are not included in the 5-minute time limit.

Although universal criteria will be used to judge all presentations, some categories are subjective by nature (i.e. workmanship). However, the Judges’ decisions are final. Please note that all members of the judging panel may not witness every presentation. However, all judges will be instructed to use the same criteria when judging a presentation and the panel will confer (with all members in attendance) before naming a winner.

Rule Violations:

- 1 point (out of 30) will be deducted for each additional 30 seconds of presentation.
- 5 points (out of 30) will be deducted for each team member that does not speak.

Display Board [15 Points]

- Every display must contain the following elements:
 - Title name (be creative).
 - School’s name.
 - All team members’ names.
 - Graphic representations of the bridge design.
 - Photographic records of the construction process.
- Displays may not exceed the following dimensions: 48” length x 36” height x 18” depth.

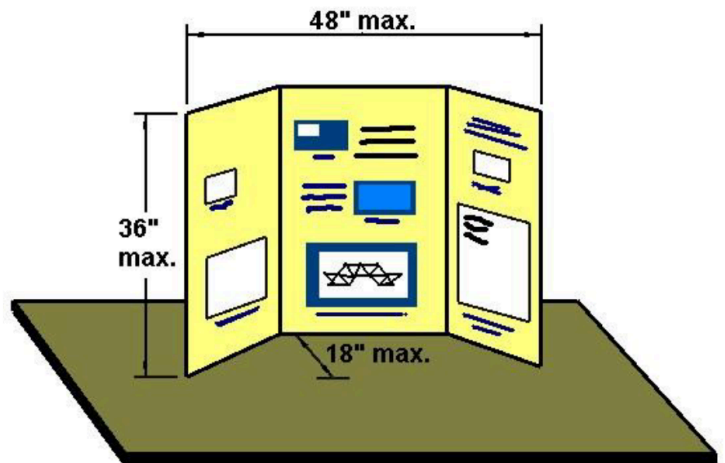

Rule Violations:

- 2 points (out of 15) will be deducted for each missing element from the display board.
- 5 points (out of 15) will be deducted for display boards exceeding the listed dimensions.

Technical Report [20 Points]

- Must have a title sheet with the school, team name, team ID, and team members.
- Body of the report shall be 2-4 pages long, not including illustrations or photographs.
- Must be typed in 12-point Arial, double-spaced.
- Must address the questions stated in “Stage 3: Presentation” on Page 8 of the rulebook.
- Must include a drawing with the dimensions of your bridge design.
- In addition to the drawing, must include 1 to 4 illustrations and/or photographs with labeled captions that document the construction of your bridge. The dimensioned drawing of the bridge does not count towards this requirement.
- Technical reports must be the original work of the team. It may not be reproduced, recycled, or reused from prior years.
- If the technical reports of any teams are the same or similar, all teams will be **disqualified**. **Disqualified teams** will not be scored and judged on the day of the competition and the sponsoring teacher will be immediately notified.

Rule Violations:

- 1 point (out of 10) will be deducted for each missing element from the technical report.
- Plagiarism will result in immediate disqualification from the competition

All report submittals are considered final. Only the first submittal will be judged. Reports must be emailed in their Final PDF format to popsicle.bridge@gmail.com by the time frames below:

Regular submittal: Reports shall be submitted by **Friday, April 4th, 2025, at 11:59 PM Pacific Standard Time** to receive the full amount of points.

Late submittal: Reports submitted after the regular submittal deadline above, shall result in a 5-point deduction. The last day to submit reports online via email (popsicle.bridge@gmail.com) is **Thursday, April 17, 2025, at 11:59 PM Pacific Standard Time**.

PDF File Name Format: To standardize our files, teams must submit technical reports by email with the following file structure: ***Full School Name_ID Number*_Team Name.pdf***

Example: Los Angeles High School_ID 415_Bridge Builder.pdf

**ID Number provided by ASCE upon online registration. May be requested by email.*

Impromptu Design Competition and Mystery Event [5 Points]

The impromptu design competition is to test every team’s skills on an engineering challenge. Materials will be provided, and each team will be responsible for designing something within the rules and conditions given during the competition. Every team will have the same challenge. Details will be provided on the day of the event.

Mystery Event [5 Points]

If necessary, a Mystery Event will also be presented on the day of the competition. The scores granted during the Mystery Event will be used for tiebreakers.

Summary

1. Build a Bridge That Can Do This

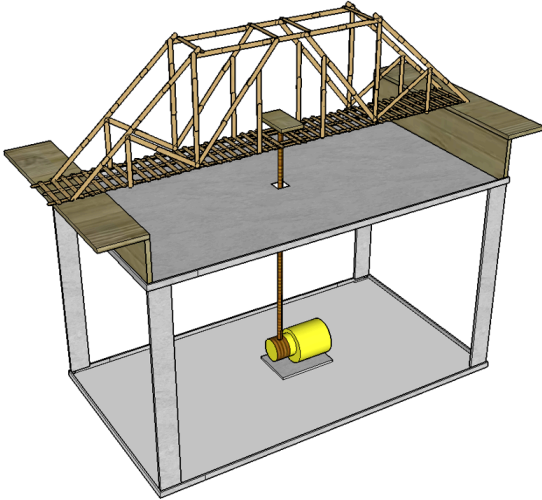

2. Out of This Stuff



+



3. Make it Light and Strong

4. Write a Report



5. Make a Poster

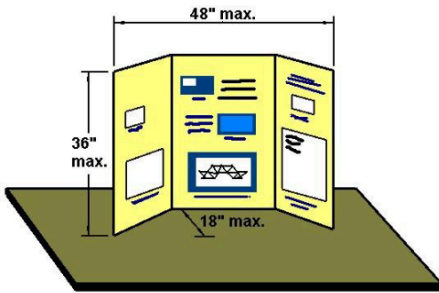

6. Present



7. MONEY \$\$\$ (Actually though, there's a scholarship prize)

